

AMPERE  **EV**

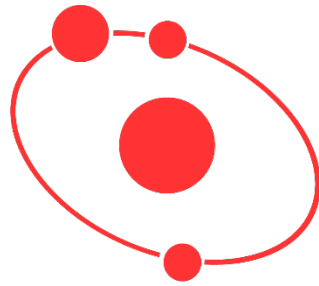

ATOM
DRIVE SYSTEM

LOW VOLTAGE WIRING HARNESS DATASHEET

Version 4.6



CONTENTS

JUNCTION BOXES.....	4
HV JUNCTION BOX.....	4
CCS JUNCTION BOX.....	5
THROTTLE	6
THROTTLE PEDAL.....	6
CABLE THROTTLE	7
SENSORS	8
VACUUM SENSOR.....	8
AC PRESSURE SENSOR	9
AMBIENT AIR TEMP SENSOR	10
BRAKE SWITCH	11
PARKING BRAKE.....	11
IGNITION.....	12
MAIN POWER RELAY	12
FANS	13
FAN 1	13
FAN 2	13
CHARGE PORT.....	14
CHARGE PORT LOW VOLTAGE.....	14
CAR SIDE	15
CHARGE PORT SIDE.....	15
MOTOR PUMP	16
BATTERY PUMP.....	17
VACUUM PUMP.....	18
CABIN HEAT PUMP	19
BATTERY HEATER.....	20
CABIN HEATER	21
AC COMPRESSOR.....	22
MOTORS	23
TESLA SDU	23
VEHICLE SIDE	23
057 SIDE.....	23
TESLA LDU.....	24



CASCADIA IM-225 25

CASCADIA IDM-190 26

TM4 SUMO LD MV400..... 27

BATTERY MODULES 28

 MODULE SIDE PINOUT 29

 HUB SIDE PINOUT 29

 3 MODULE DIAGRAM 30

 6 MODULE DIAGRAM 31

CHARGERS 32

 OVAR TECH CHARGER..... 32

 DILONG CHARGER 33

GUI..... 34

CAN KEYPAD 35

FUSE BOX..... 36

BRAKE LIGHTS 38

REVERSE LIGHTS 38

AC FAN RELAYS 39

ELECTRIC PARKING BRAKE 40

PARK PAWL..... 41

AUX POWER..... 42

TOOLS AND CRIMPERS 43

 HYDRAULIC CRIMP TOOLS 43

 HAND CRIMP TOOLS..... 44

 CUTTING TOOLS..... 45

 WIRE STRIPPERS 46

REVISION HISTORY..... 47



JUNCTION BOXES

HV JUNCTION BOX



PIN	COLOR	DESCRIPTION
01	Blue	MAIN - CTR FEEDBACK
02	Red	MAIN - CTR 12V
03	Red	PRECHARGE RELAY 12V
04	Yellow	DISCHARGE RELAY 12V
05	Grey	JB HVIL IN
06		Reserved
07	Orange	MAIN - CTR FEEDBACK
08	Black	JB GND 1
09	Black	JB GND 2
10	Black	JB GND 3
11	Black	JB HVIL OUT
12		Reserved



CCS JUNCTION BOX



Wire Bundle 4

PIN	COLOR	DESCRIPTION
01	Grey	CCS + CTR FEEDBACK
02	Yellow	CCS – CTR FEEDBACK
03	White	CCS VS 12V
04	Pink	CCS CTR 12V
05	Purple	CCS HVIL IN
06	Green	Can Lo
07	Red	CCS + CTR FEEDBACK
08	Orange	CCS – CTR FEEDBACK
09	Black	CCS GND 1
10	Black	CCS GND 2
11	Green	CCS HVIL OUT
12	Yellow	CAN hi



THROTTLE

THROTTLE PEDAL



Wire bundle 17

PIN	COLOR	DESCRIPTION
01	Red	THROTTLE 2 5V
02	Blue	THROTTLE 1 5V
03	Black	THROTTLE 1 GND
04	Yellow	THROTTLE 1 SIGNAL
05	Grey	THROTTLE 2 GND
06	Orange	THROTTLE 2 SIGNAL



CABLE THROTTLE



PIN	COLOR	DESCRIPTION
01	Red	THROTTLE 2 5V
02	Grey	THROTTLE 2 GND
03	Orange	THROTTLE 2 SIGNAL
04	Yellow	THROTTLE 1 SIGNAL 3
05	Blue	THROTTLE 1 5V
06	Black	THROTTLE 1 GND



SENSORS

VACUUM SENSOR



PIN	COLOR	DESCRIPTION
01	Blue	VAC SENSOR 5V
02	Grey	VAC SENSOR GND
03	Yellow	VAC SENSOR SIGNAL



AC PRESSURE SENSOR

The AC pressure sensor comes with a pre-terminated pigtail. Use the supplied heat shrink butt connectors and heat shrink to attach the wires to the Atom Drive Harness.

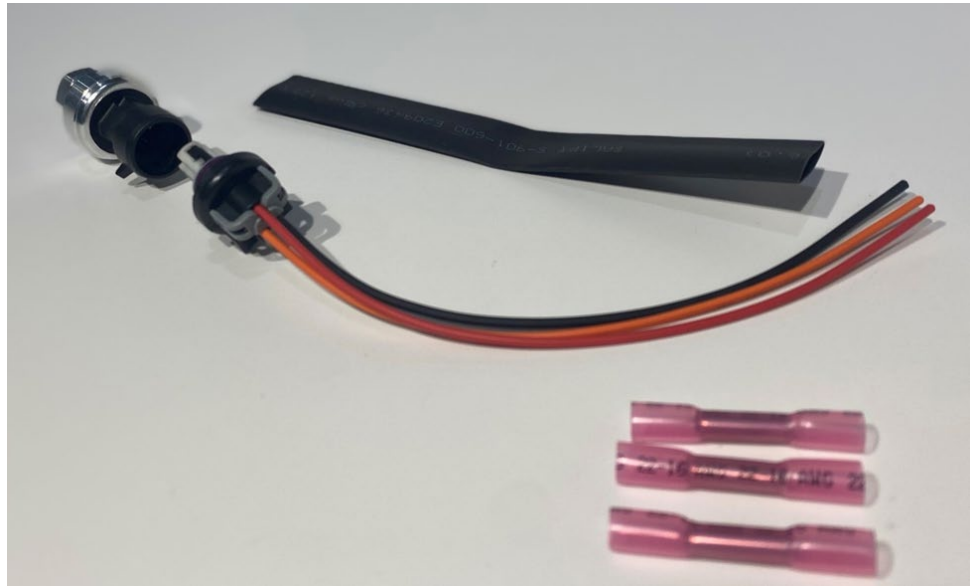

Wire Bundle 12

PIN	COLOR	DESCRIPTION
01	Black	AC PRESS SIGNAL
02	Green	AC PRESS GND
03	Grey	AC PRESS 5V



AMBIENT AIR TEMP SENSOR

The Ambient air temperature sensor is an important part of the Atom Drive control system. Be sure to mount the sensor in a location where it will be able to measure ambient air conditions. Common locations are behind the front grille, bumper, or any other protected location away from excessive heat. The wires for this sensor are found in bundle 13.

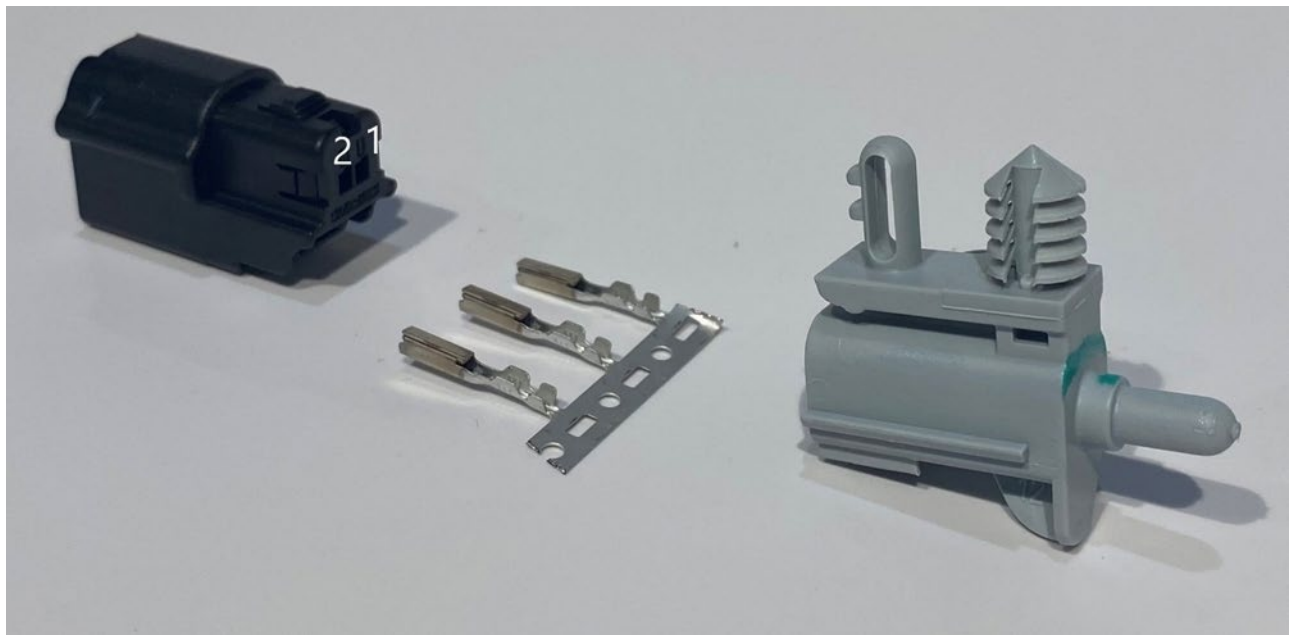

PIN	COLOR	DESCRIPTION
01	Blue	Air Temp Signal
02	Black	Sensor GND



BRAKE SWITCH

In order to know which wire to use for the brake switch, you must first determine whether the vehicle's brake switch pulls to ground, or 12 volts. If the switch goes to ground, use wire labeled "BRAKE SWITCH LO". If the switch output pulls high to 12V when activated, use the wire labeled "BRAKE SWITCH HI". Use only one wire or the other. No special settings or calibrations are needed as the VCU will automatically detect which wire is being used. Leave the unused wire unterminated. It is good practice to apply some tape or heat shrink over the end of the unused wire to be sure it is not activated inadvertently.

PIN	COLOR	DESCRIPTION
01	Black	BRAKE SWITCH LO
02	Blue	BRAKE SWITCH HI

Note

If the vehicles brake switch directly drives the brake light relay, it will be necessary to sever this connection so that only the VCU controls the brake lights. Failure to disconnect the direct control from the brake switch may result in the brake lights turning on, but not ever turning off.

PARKING BRAKE

The Atom Drive System is designed to accept a low side trigger (pull to ground) input for the manual parking brake. When engaged, the wire should be grounded. When disengaged the wire should be floating (not connected to a power or ground source). The parking brake input wire is labeled "PARK BRAKE LO". The parking brake input wire is not required to be connected to the car; however, there is logic inside the VCU to prevent the vehicle from trying to move or go into drive mode when the parking brake is applied. If the parking brake wire is not connected, this functionality will not be operational. Additionally, the parking brake light will not display on the user interface screen when the parking brake is applied. The vehicle will otherwise function normally without the parking brake input.

PIN	COLOR	DESCRIPTION
01	Grey	PARK BRAKE LO



IGNITION

The Ignition wire is a high side trigger wire which initiates the startup and shut down procedures within the VCU control logic. This wire can be connected to any wire with 12V when the vehicle is keyed on. You can use the output wires from the ignition barrel if using a standard key or even a simple toggle switch connected to constant power. This decision is up to you as long as the wire is powered when the vehicle is intended to be on and not powered when the vehicle is intended to be off.

PIN	COLOR	DESCRIPTION
01	Black	IGNITION

MAIN POWER RELAY

The Main Power Relay controls the switched power to the entire system. The relay is controlled directly by the VCU as part of the startup and shut down procedures. This relay should be mounted and wired according to the Atom drive 12V schematic. The coil of the relay will be controlled via the two wires in the VCU pigtail harness labeled “MPR DRIVER” and “MPR CONST 12V”. It does not matter which blade of the relay coil the two wires are connected to.

PIN	COLOR	DESCRIPTION
01	Black	MPR DRIVER
02	Red	MPR CONST 12V



FANS

The wires coming from the fan should be pinned to the male connector, and the car side to the female connector. The 12V input to the fan is blue, and the ground is black. Connect the blue wire to pin 01 on the fan side connector. **NOTE:** Both fans are identical assemblies; however, they are **NOT** interchangeable from a wiring perspective. Be sure to connect fan 1 to the correct connector and wires for fan 1 on the car side of the harness and vice versa. If the fans are wired improperly, the VCU will not be able to control the cooling system appropriately for the respective cooling loops in addition to AC condenser cooling.

FAN 1

FAN SIDE CONNECTOR

PIN	COLOR	DESCRIPTION
01	Blue	Fan 1 12V
02	Black	Fan 1 GND

CAR SIDE CONNECTOR

PIN	COLOR	DESCRIPTION
01	Light Green	Fan 1 12V
02	Black	Fan 1 GND

FAN 2

FAN SIDE CONNECTOR

PIN	COLOR	DESCRIPTION
01	Blue	FAN 2 12V
02	Black	FAN 2 GND

CAR SIDE CONNECTOR

PIN	COLOR	DESCRIPTION
01	Blue	FAN 2 12V
02	Black	FAN 2 GND



CHARGE PORT

The charge port supplied with the Atom Drive System includes features such as a charge port lock motor and thermistors to monitor the temperature of the power pins for both AC and DC fast charging if equipped. The wires for these features, as well as proximity and pilot control wires, are supplied coiled with several feet of length from the charge port itself. It is up to the installer how long or short to leave these wires. The main factor of importance is that enough slack be left between the car side and charge port side of the harness so that the wires can be routed and tucked away as desired. It is good practice to determine your proper length so that the two ends meet exactly along your desired routing path and then add a few inches to each side to avoid cutting the harnesses too short by mistake. It is far easier to cut a wire long than to lengthen it after cutting it too short by mistake.

There is a large gauge green and yellow positive earth wire from the charge port which should be grounded to the vehicle chassis. One possible location for this is the ground lug on the charger itself. The Positive Earth (PE) wire coming from the low voltage connector on the charge port side should be routed to the same chassis ground location as the green and yellow PE wire. A 4ga Lug and black wire with M8 ring terminal have been included for the PE grounds.

CHARGE PORT LOW VOLTAGE

NOTE: Pin one side of the supplied black wire with the M8 ring terminal in the PE ground kit to pin 7 on the charge port side connector. Bolt the other end to the same ground location you choose for the 4ga green and yellow PE cable coming from the charge port. A good location, if convenient, is the ground lug on the charger unit itself. You must make sure that the ground lug on the charger is also supplied with a good chassis ground using 8ga or larger cable.

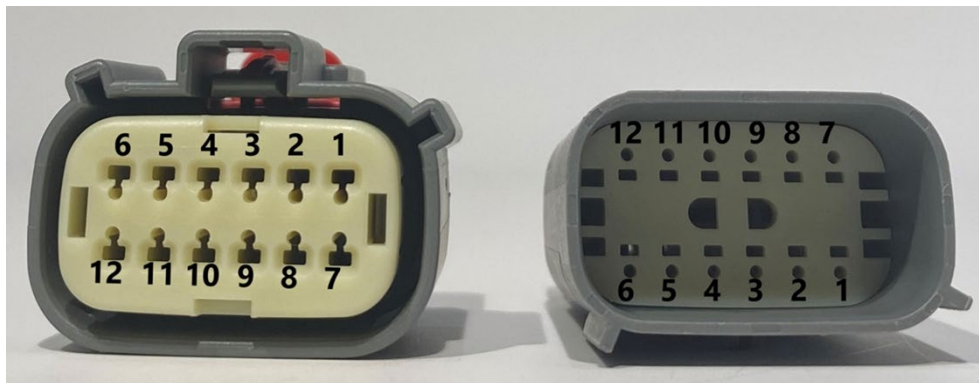



CAR SIDE

PIN	COLOR	DESCRIPTION
01	Black	AC Temp
02	Grey	AC Temp GND
03	Blue	DC Temp GND
04	Brown	DC- Temp
05	White	DC+ Temp
06	Blue	EVSE CP
07	Red	EVSE PE
08	Yellow	EVSE Prox
09	Green	Plug Lock +
10	Pink	Plug Lock -
11	Purple	Lock Pos Feedback +
12	Orange	Lock Pos Feedback -

CHARGE PORT SIDE

PIN	COLOR	DESCRIPTION
01	Grey	AC Thermistor Signal
02	Brown	AC Thermistor GND
03	Brown	DC Thermistor GND
04	Green	DC- Thermistor Signal
05	Yellow	DC+ Thermistor Signal
06	White	EVSE Control Pilot
07	Black	EVSE PE(GND w/ yellow/green cable)
08	Black	EVSE Proximity
09	Blue/Red	Plug Lock Motor +
10	Blue/Brown	Plug Lock Motor -
11	Blue/Green	Lock Position Feedback +
12	Blue/ Yellow	Lock Position Feedback -



MOTOR PUMP

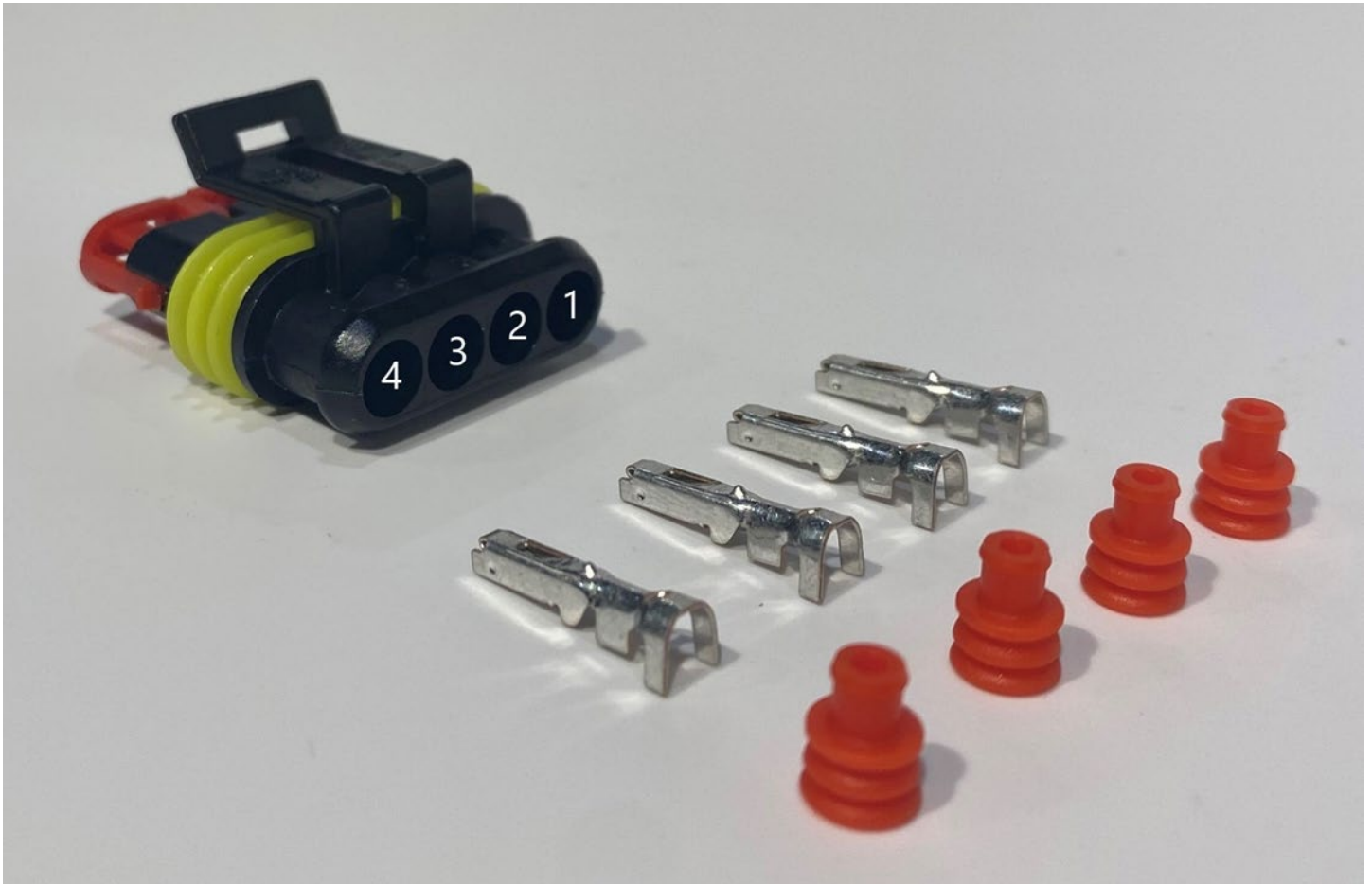

Wire Bundle 24

PIN	COLOR	DESCRIPTION
01	Pink	MOTOR PUMP MPR 12V
02	Yellow	MOTOR PUMP CAN HI
03	Green	MOTOR PUMP CAN LO
04	Red	MOTOR PUMP GND



BATTERY PUMP

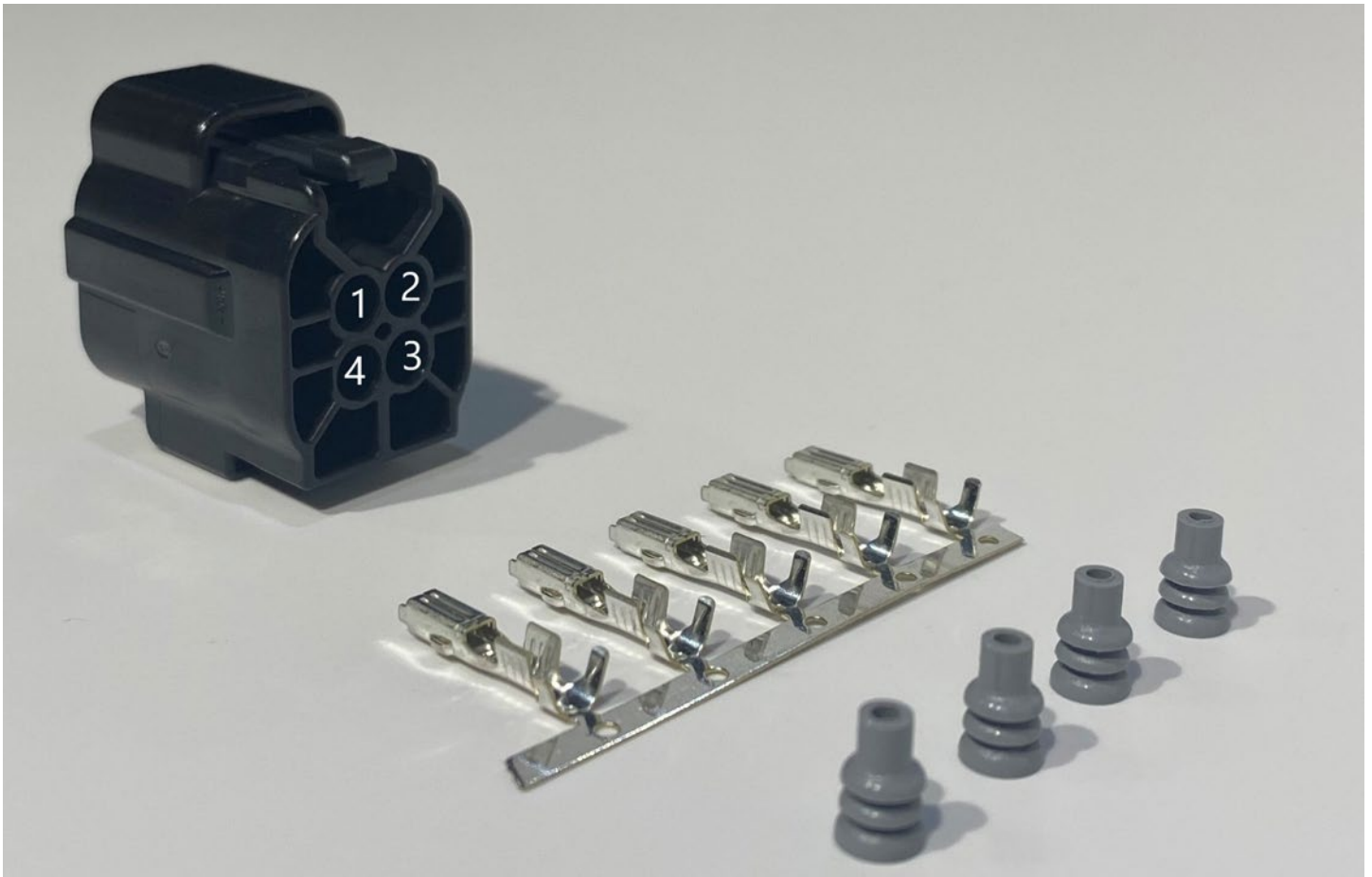

Wire bundle 27

PIN	COLOR	DESCRIPTION
01	Black	BATT PUMP GND
02	Yellow	BATT PUMP CAN HI
03	Green	BATT PUMP CAN LO
04	Pink	BATT PUMP MPR 12V



VACUUM PUMP

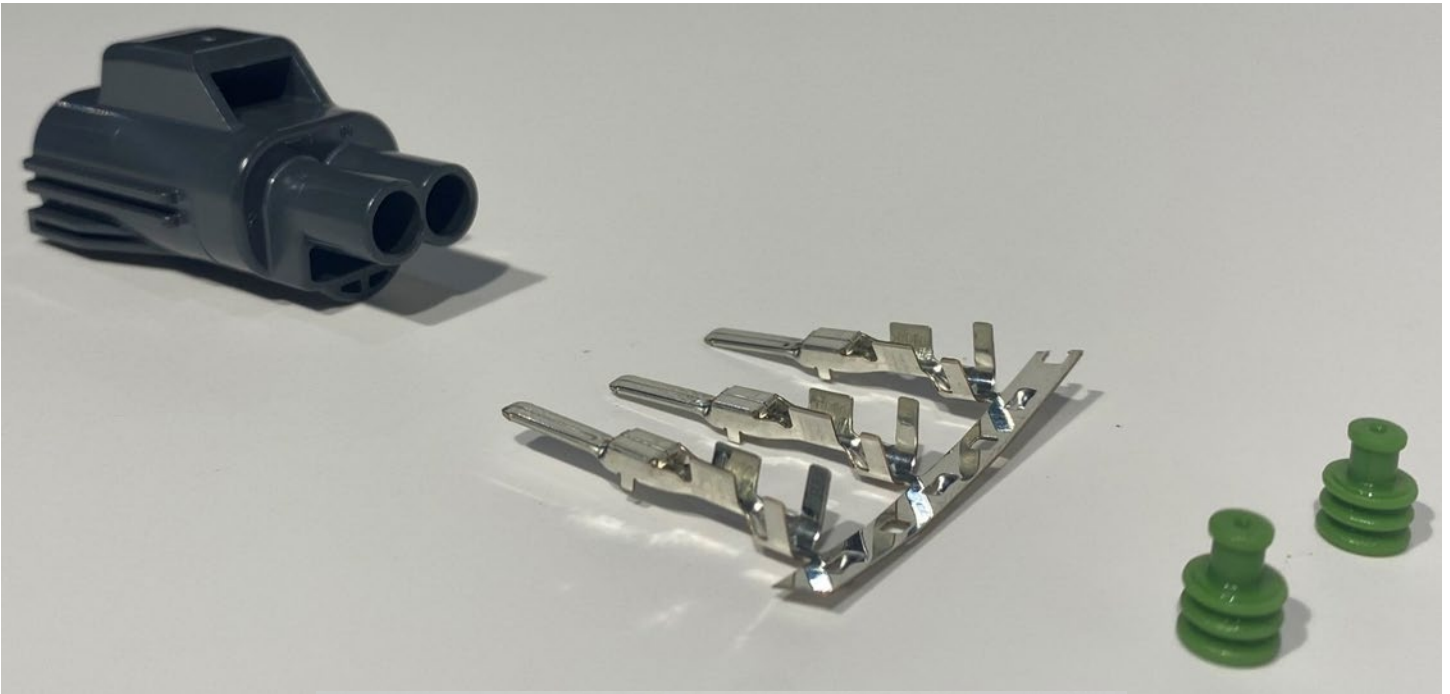

Wire Bundle 25

PIN	COLOR	DESCRIPTION
01	Pink	VAC PUMP 12V
02	Black	VACUUM PUMP GND



CABIN HEAT PUMP

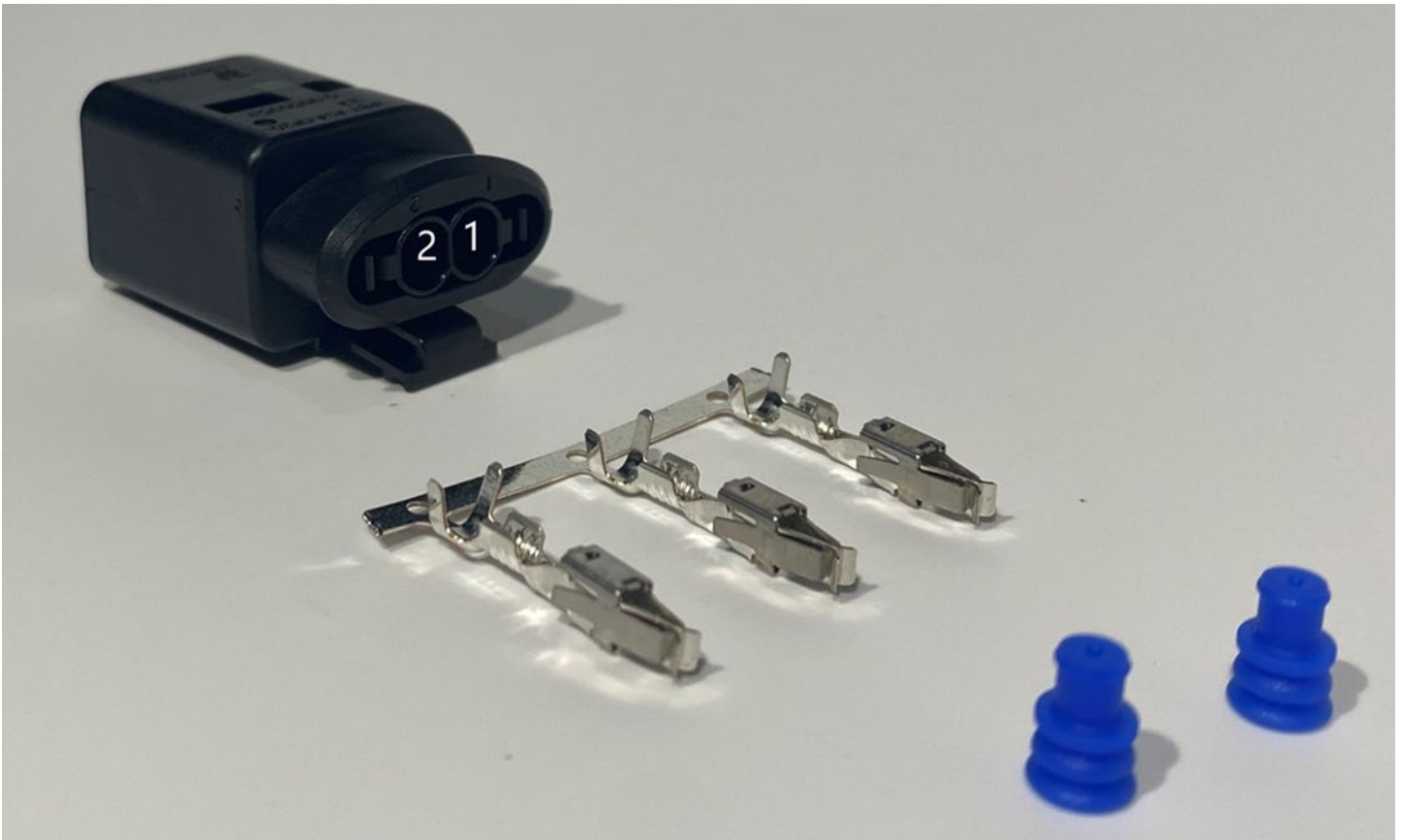

PIN	COLOR	DESCRIPTION
01	Green	Cabin Heat Pump 12V
02	Black	Cabin Heat Pump GND



BATTERY HEATER



PIN	COLOR	DESCRIPTION
01		
02	Yellow	BATT HEAT CAN HI
03	Green	BATT HEAT CAN LO
04	Black	BATT HEAT GND
05	Light Green	BATT HEAT 12V
06		



CABIN HEATER



Wire Bundle 29

PIN	COLOR	DESCRIPTION
01		
02	Yellow	CABIN HEAT CAN HIGH
03	Green	CABIN HEAT CAN LOW
04	Black	CABIN HEAT GND
05	Red	CABIN HEAT 12V
06		



AC COMPRESSOR



Wire Bundle 26

PIN	COLOR	DESCRIPTION
01	Green	AC COMP CAN LO
02	Yellow	AC COMP CAN HI
03	Black	AC COMP GND
04		
05		
06	Pink	AC COMP 12V



MOTORS

TESLA SDU

The Motor connector connects the VCU pigtail harness to the 057 control module harness. It does not matter which side is pinned to which connector (male side connector with green wedge lock not shown). There will be many unused wires in the 057 harness. To interface with the Atom Drive System controls, all that is needed are CAN, power, and ground. These wires are White/Red, Blue, Red, and Black. Wires are found in bundle 23.



VEHICLE SIDE

PIN	COLOR	DESCRIPTION
01	Yellow	MOTOR CAN HI
02	Green	MOTOR CAN LO
03	Black	MOTOR GND
04	Orange	MOTOR ENABLE

057 SIDE

PIN	COLOR	DESCRIPTION
01	White/Red	Motor CAN hi
02	Blue	Motor CAN lo
03	Black	Motor GND
04	Red	Motor 12V



TESLA LDU

LEFT INTENTIONALLY
BLANK FOR FUTURE
ADDITIONAL
INFORMATION



CASCADIA IM-225



Wire Bundle 23

PIN	COLOR	DESCRIPTION
01	Yellow	MOTOR CAN HI
02	Green	MOTOR CAN LO
03	Orange	MOTOR ENABLE
04	Pink	AUX POWER 1
05	Black	MOTOR CONTROL GND
06		



CASCADIA IDM-190



Wire Bundle 23

PIN	COLOR	DESCRIPTION
01	Yellow	MOTOR CAN HI
02	Green	MOTOR CAN LO
03	Orange	MOTOR ENABLE
04	Pink	AUX POWER 1
05	Black	MOTOR CONTROL GND
06		



TM4 SUMO LD MV400

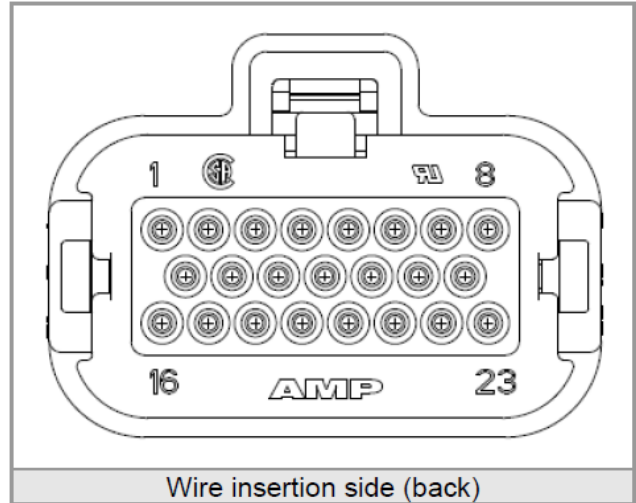
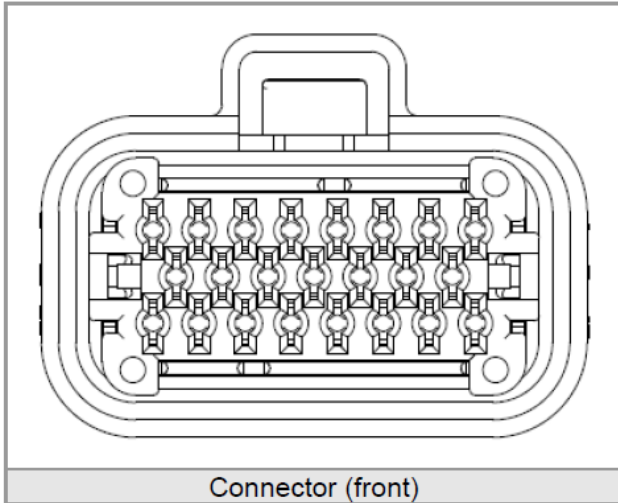

Wire Bundle 23

PIN	COLOR	DESCRIPTION
01	Pink	MOTOR MPR 12V
08	Orange	MOTOR ENABLE
09	Green	MOTOR CAN LO
15	Orange	MOTOR ENABLE
16	Yellow	MOTOR CAN HI
22	Black	MOTOR CONTROL GND
23	Black	MOTOR CONTROL GND



BATTERY MODULES

The Atom Drive battery system makes use of 5-way connector hubs to simplify the system wiring. There will be one hub in a 3-module system and 2 hubs in a 6-module system. The connector hub connects to the VCU pigtail harness with an Aptiv GT150 10-way connector using the wires from branch number 14. The pinout for this is below. From the hub, each module will connect with the same GT150 connector on the hub side and a 12 pin Molex MX150 connector on the battery module side. If the system uses 6 modules, then two connector hubs will need to be chained together using the GT150 connector on both sides. Since the connector hub pins are all bridged internally, it does not matter which connector goes where on the hub itself. In other words, there is no right or wrong order in which to connect the modules to the hub.

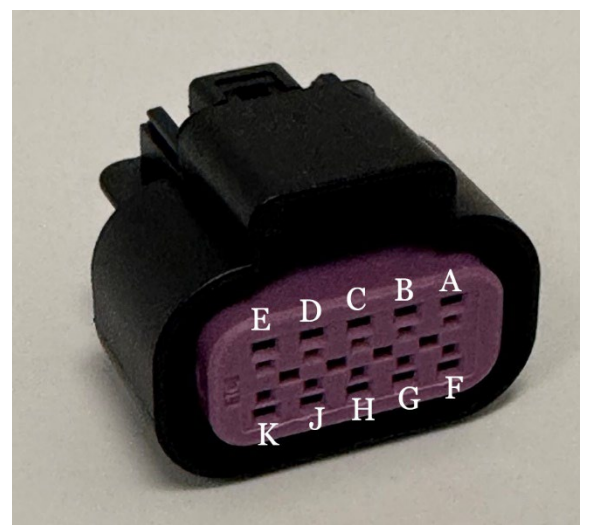
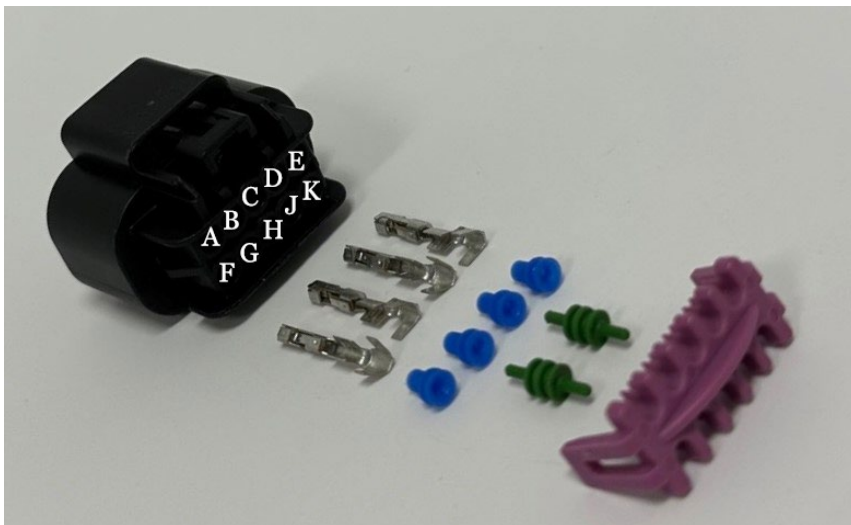



MODULE SIDE PINOUT

PIN	COLOR	DESCRIPTION
01	Pink	BMS MPR 12V
02	Black	BMS GND
03	Yellow	BMS CAN 0 HI
04	Green	BMS CAN 0 LO
05	Orange	BMS FAULT
06	Yellow	BMS WAKE
07	Yellow	BMS CAN 1 HI
08	Green	BMS CAN 1 LO
09		
10		
11		
12		

HUB SIDE PINOUT

PIN	COLOR	DESCRIPTION
A	Pink	BMS MPR 12V
B	Black	BMS GND
C	Yellow	BMS CAN 0 HI
D	Green	BMS CAN 0 LO
E	Orange	BMS Fault
F	Yellow	BMS VCU Wake
G	Yellow	BMS CAN 1 HI
H	Green	BMS CAN 1 LO
I		
J		



3 MODULE DIAGRAM

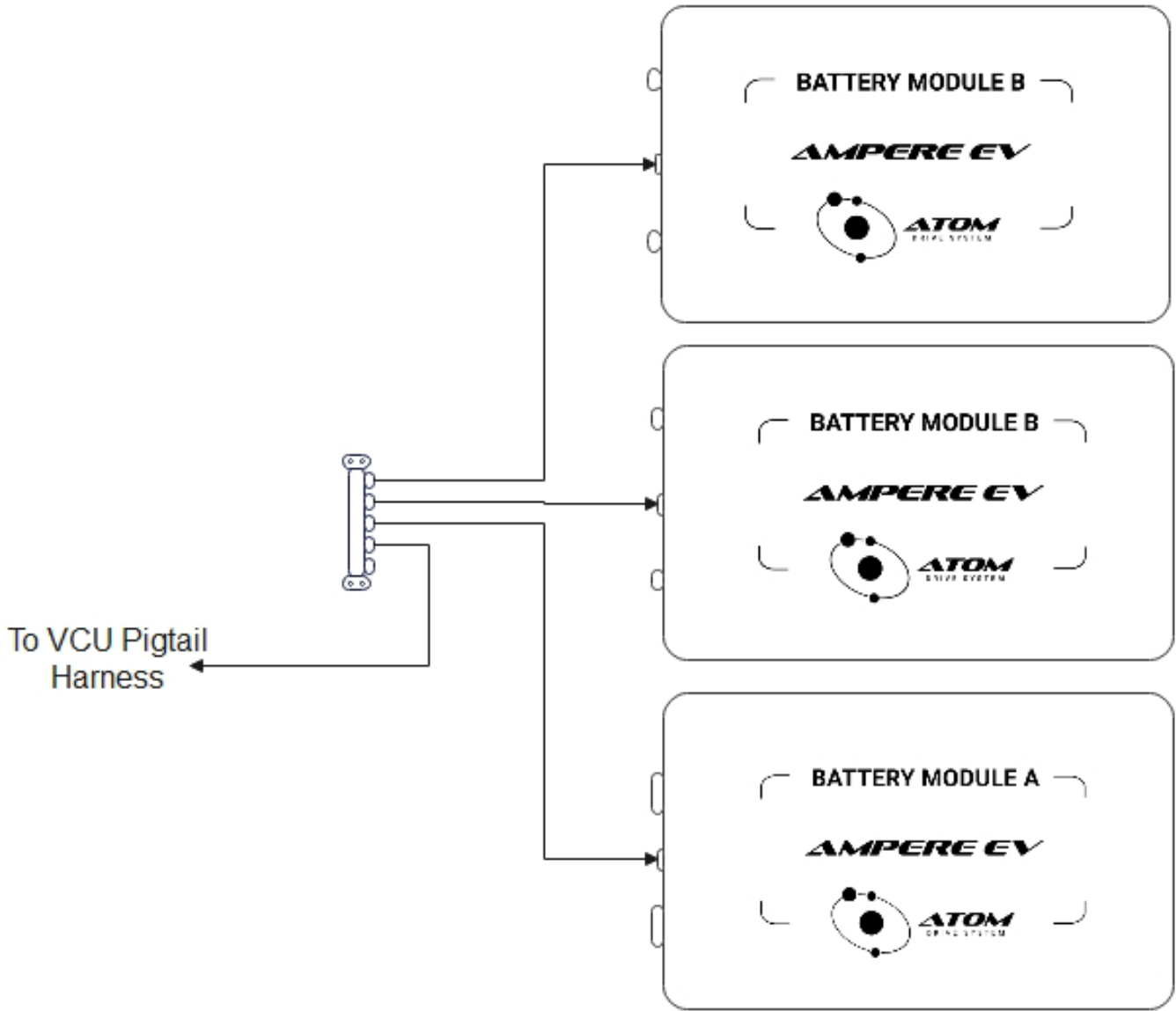



6 MODULE DIAGRAM

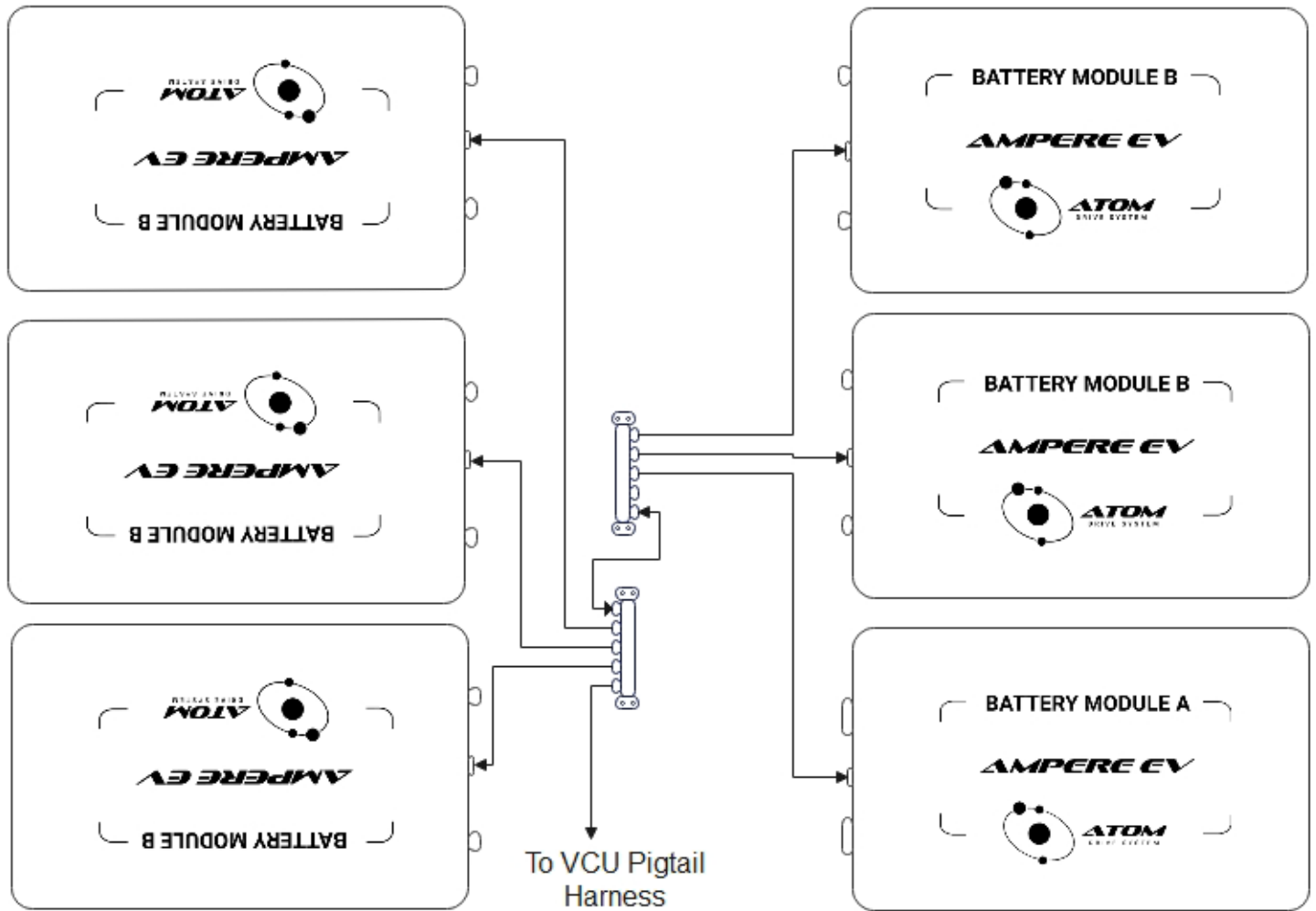



CHARGERS

OVAR TECH CHARGER

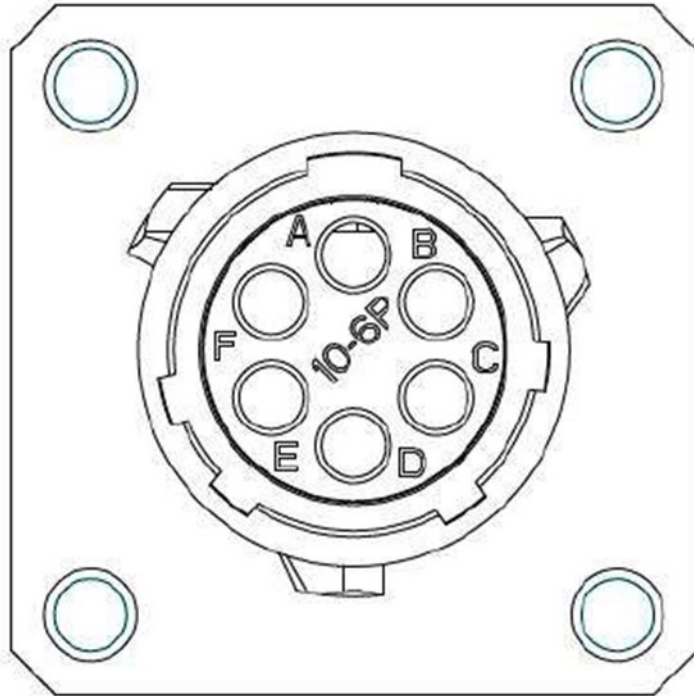

Wire Bundle 19

PIN	COLOR	DESCRIPTION
A	Green	CHARGER CAN LO
B	Yellow	CHARGER CAN HI
C		
D	Pink	CHARGER MPR 12V
E	Black	CHARGER GND
F	Orange	DC/DC ENABLE



DILONG CHARGER

LEFT INTENTIONALLY
BLANK FOR FUTURE
ADDITIONAL
INFORMATION



GUI

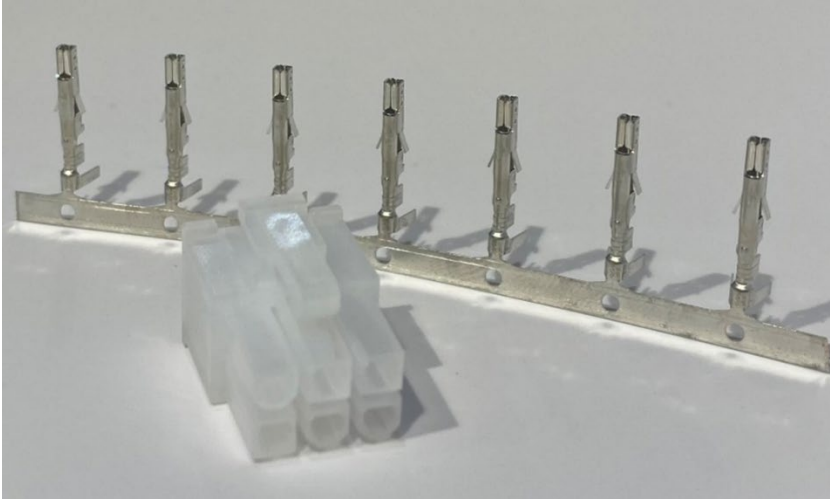

Wire Bundle 20

PIN	COLOR	DESCRIPTION
01	Red	GUI CONST 12V
02	Pink	GUI 12V
03	Black	GUI GND
04	Yellow	GUI CAN HI
05	Green	GUI CAN LO
06		



CAN KEYPAD

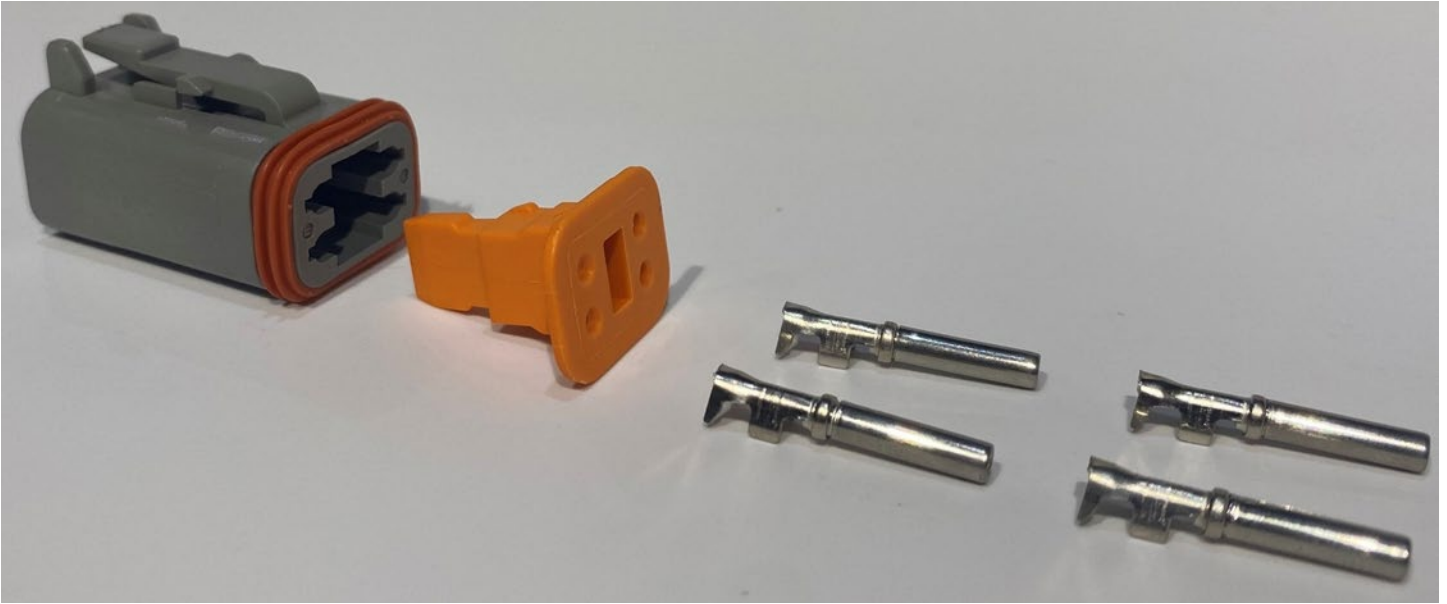

PIN	COLOR	DESCRIPTION
01	Green	CAN LO
02	Yellow	CAN HI
03	Black	CAN KEYPAD GND
04	Pink	KEYPAD MPR 12V





FUSE BOX

The Atom Drive System utilizes a dual rail fuse box to distribute constant power, as well as main power relay switched power. The larger power rail should be connected to the output of the main power relay and feeds pin positions 01 through 14. Constant power from the vehicle's 12V battery is supplied to the smaller rail, feeding pin positions 15 through 20.

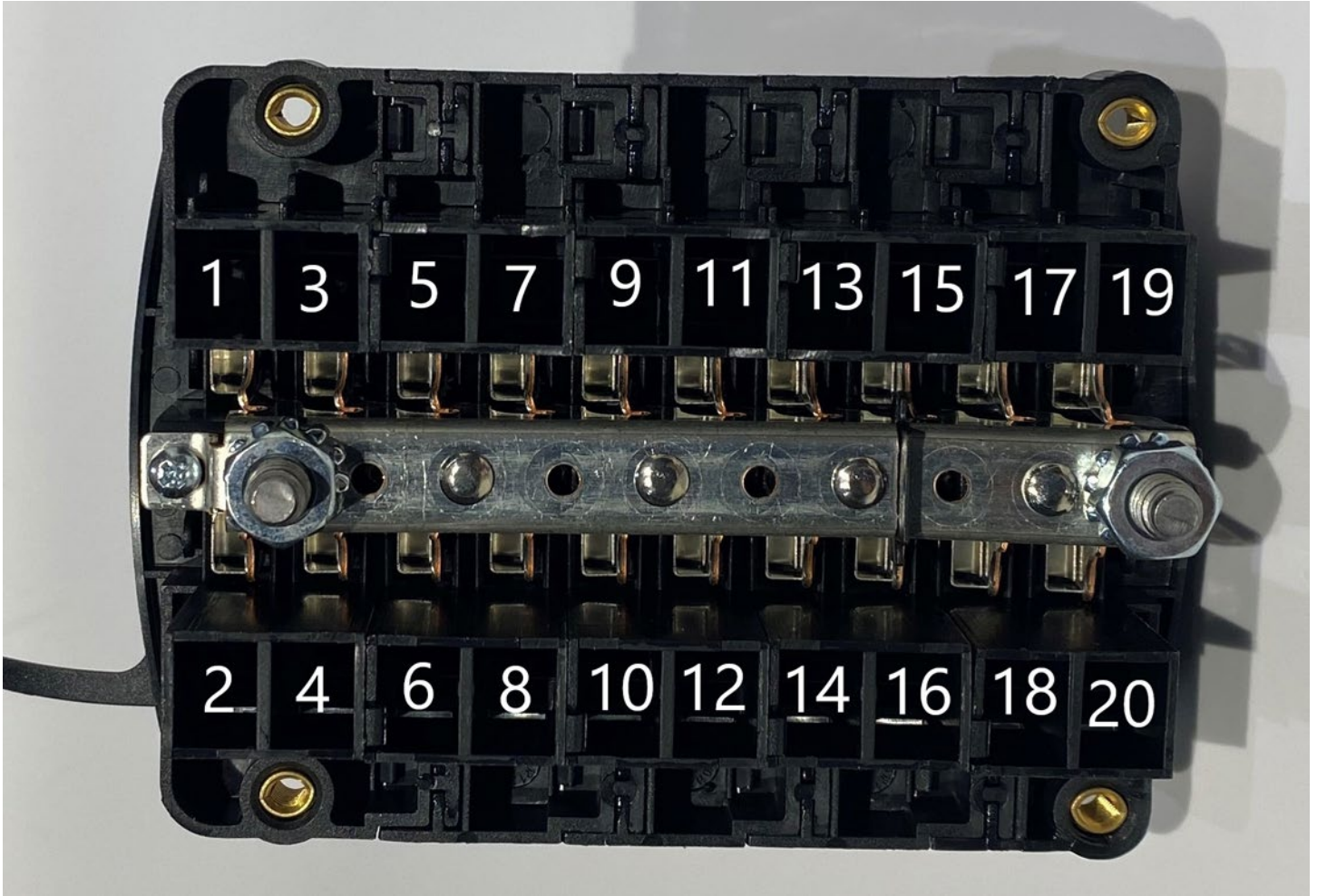



PIN	COLOR	DESCRIPTION
01	Pink	BMS MPR 12V
02	Pink	KEYPAD MPR 12V
03	Pink	CHARGER MPR 12V
04	Pink	MOTOR PUMP MPR 12V
05	Pink	BATT PUMP MPR 12V
06	Pink	MOTOR MPR 12V
07	Pink	AUX POWER 2
08	Pink	AUX POWER 3
09	Red	VCU MPR 12V
10	Red	VCU MPR 12V
11	Red	VCU MPR 12V
12		
13		
14		
15	Red	VECTOR CONST 12V
16	Red	GUI CONST 12V
17	Red	MPR CONST 12V
18	Pink	AUX POWER 1
19	Red	BMS CONST 12V
20		



BRAKE LIGHTS

The Atom Drive System is configured to control the vehicle's brake lights. This functionality can be in addition to your existing vehicle wiring or separate. When the brakes are applied, the control system will automatically enable the brake lights. It is important to allow the VCU control over the brake lights to ensure that they come on appropriately under both mechanical braking and regenerative braking events. For this functionality to work, the brake light control wire "BRAKE LIGHTS 12V" should be spliced into the 12V power wire for the brake lights in the vehicle.

Wire Bundle 16

PIN	COLOR	DESCRIPTION
	Red	BRAKE LIGHTS 12V

REVERSE LIGHTS

The Atom Drive System is configured to control reverse lights. This functionality can be in addition to your existing vehicle wiring or separate. When reverse is selected on the CAN keypad, the control system will automatically enable the reverse lights. For this functionality to work, the reverse light control wire "REVERSE LIGHTS 12V" should be spliced into the 12V power wire for the reverse lights in the vehicle.

Wire Bundle 16

PIN	COLOR	DESCRIPTION
	Blue	REVERSE LIGHTS 12V



AC FAN RELAYS

The Atom Drive System can control fans for the AC system in two different ways. Firstly, the two supplied fluid coolers can be placed directly behind the AC condenser such as would be found in an OEM vehicle setup. In this case, the fans are preconfigured to also engage when the AC system needs cooling separately from the other cooling loops in the vehicle. This may not be practical or possible in all applications and as such, the wiring harness includes two low side wires to control relays for AC condenser fans. These fans and relays are not included in the kit but can be wired in with the auxiliary power wires found in the harness to control remotely mounted AC condenser fans as needed. To use these wires in that way, connect the relay coil and input to one of the auxiliary power wires. Connect the output of the relay to one side of the fan and connect an auxiliary ground wire to the other. The AC FAN 1 RELAY (or both if there are two fans) wire should be connected to the other side of the relay coil. The control logic is preconfigured to recognize this change and will work properly without any other configuration or software modification.

PIN	COLOR	DESCRIPTION
	Green	AC Fan 1 Relay
	Yellow	AC Fan 2 Relay



ELECTRIC PARKING BRAKE

LEFT INTENTIONALLY
BLANK FOR FUTURE
ADDITIONAL
INFORMATION



PARK PAWL

The Cascadia motion IM225 and IDM190 motors include a motorized parking pawl which acts as an electronic parking brake. This portion of the wiring only applies to those Cascadia products as of January 2023. These motors will be supplied with a park pawl patch harness which introduces 2 additional power relays and interfaces with the park pawl motor connector.



PIN	COLOR	DESCRIPTION
01	White	PARK PAWL FEEDBACK GND
02	Grey	PARK PAWL FEEDBACK A
03	Orange	PARK PAWL FEEDBACK B
04	Red	PARK PAWL FEEDBACK C
05	Yellow	PARK PAWL FEEDBACK D
06	Purple	PARKING BRAKE +
07	Blue	PARKING BRAKE -
08	Pink	AUX POWER 2
09	Black	AUX GND 2



AUX POWER

There are 2 additional auxiliary power and ground wires included in the harness for use at the customers discretion. These wires should be taped off or heat shrunk to ensure they do not short to ground if not used.



TOOLS AND CRIMPERS

The tools and crimpers listed here are not absolutely required for installation; however, they can improve the ease of install substantially. This is particularly true for the Molex factory crimp tools, which while expensive, result in a very good very easy to install crimp.

HYDRAULIC CRIMP TOOLS

HYCLAT HWC007000 Hydraulic Crimping Tool

This Hydraulic crimp tool from HYCLAT is great for small to medium gauge crimping duties. We use this tool for all of the 8-gauge lugs used in the 12V wiring as well as for some of the smaller HV wires for the charger and DCDC.



WBHome Hydraulic Crimping Tool

This or any other 12+ Ton crimping tool, easily found on Amazon, will provide a good crimp on the 50mm² and 70mm² HV terminals connecting the battery and motor to the HV junction box.





HAND CRIMP TOOLS

For crimping the individual pins for all the various connectors, it may be preferred to have several different styles of crimping tool. Some just tend to work better than others when you are not using the manufacturer suggested crimp tools which are often excessively expensive or just simply unavailable. The following tools are some of our favorites and/or what we have made work in the past. Most of these are readily available and affordable from vendors such as Amazon.

IWISS IWS-1440L for AWG 28-14 Open Barrel Crimping Tool

This crimp tool from IWISS is a good all-around crimper for many different types of open barrel crimps. This tool is particularly good for tiny to small terminals and wire.



Klein Tools VDV200-010 Ratcheting Crimper

The Klein VDV200 ratcheting crimp tool accepts different die sets for different crimp types. The VDV200 with the Barrel 10-20 AWG die set makes a good general purpose crimp tool for larger bulkier terminals.



Molex 63811-6000 Crimp Tool for MX150 Series Connectors

This Molex factory crimp tool is expensive but worth every penny when time and quality are important factors. This tool makes a perfect crimp every time and is also very easy and quick to use. Consider this tool a valuable investment for your time.





CUTTING TOOLS

TEMCo TH0001 4/0 Cable Cutter

This heavy-duty cable cutter makes quick work cutting through the shielded HV cabling as well as the smaller 8 and 10 gauge cabling found in the Atom Drive System.



Klein Tools D275-5 Diagonal Cutting Pliers

These flush cut snips are very sharp and a great tool for trimming individual wires to length.



Klein Tools D248-8 Diagonal Cutting Pliers

This general-purpose set of cutters is good for cutting through small bundles of wire and nylon braid.





WIRE STRIPPERS

Klein Tools 11063W Wire Cutter / Wire Stripper

These wire strippers are by far the best tool for the money we have found. They do a great job and are much easier to use than the plier type strippers.





REVISION HISTORY

Version	Description of Version/Changes	Updated by	Date
1.0	First version of a document to match VCU pigtail wire numbers to connector pin positions.	Blakely Fabiani	3/18/22
2.0	Reformatted version of 1.0 including individual connector information.	Blakely Fabiani	5/7/22
3.0	Third formatting revision. Moved to word doc with searchable table of contents format.	Vinnie Dekarski	7/8/222
3.1	Rebuilt all tables inside of word to replace the static table images generated in Edraw.	Josh Chang	8/12/22
3.2	Added wire numbering scheme to match VCU pigtails built by JCC wiring company.	Blakely Fabiani	11/11/22
4.0	Updated wiring naming scheme to match production harnesses. Added new chargers, motors, and new battery wiring info.	Blakely Fabiani	1/11/23
4.1	Added a new section for tool recommendations.	Blakely Fabiani	1/18/23
4.2	Formatting and readability changes.	Blakely Fabiani	1/19/23
4.3	Fixed Motor Enable wire color error in Cascadia motor pinouts.	Blakely Fabiani	1/19/23
4.4	Fixed AC pressure sensor 5v and ground wires	Blakely Fabiani	1/31/23
4.5	Added Version Number to Document Cover Page	Blakely Fabiani	2/1/23
4.6	Fixed charge port AC thermistor wire color on the charge port side.	Blakely Fabiani	3/9/23